

MS-3300

경고등 LED Warning Light

□ G2B 식별번호

• 황색 /MS-3300	
---------------	--



• MS-3300

□ 설치용 암대 / Arm Bracket



□ 도면 / CAD

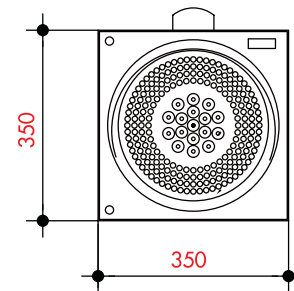

□ 시공 / Install



• 고정용 브라켓트 지주
• Bracket Pole

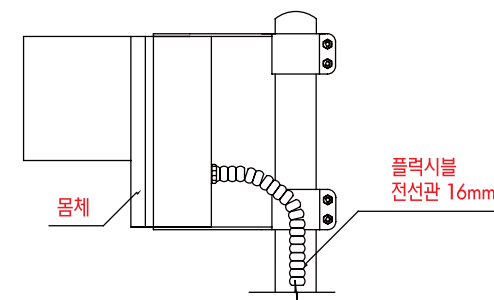

□ 규격 / Specification

* 모델 Model	MS-3300
* 크기 Size	D350 × H350 (3000)
* 무게 Weight	±5.0Kg
* 재료 Material	Body : PC
* 방수 W-proof	IP 65
* 색상 Color	Yellow.
* 램프 Lamp	LED Lamp
* 전원 Power	AC220V / ≤18.0W



□ 옵션 / Options

• LED색상.	LED Color
• 점멸/점등	Steady or Flashing Mode

□ 적용 / Application

- * 사고 위험지역
- * 안전지대, 진/출입로
- * 안개지역, 갓길
- * 인터체인지
- * 해안도로
- * Accident prone locations
- * Hazard marking
- * Pedestrian trails
- * Fog hazard areas
- * Shoulder. Curves

